

GUIDELINES FOR CONTESTABILITY IN NEW CONNECTIONS TO THE ELECTRICITY DISTRIBUTION SYSTEM IN NORTHERN IRELAND

EFFECTIVE FROM 28 MARCH 2018



TABLE OF CONTENTS

	Page
Section A – Introduction	1
Section B – Distribution Transitional Arrangements and the Scope of Contestability	6
Section C – The Application Process	13
Section D – The Issue and Acceptance of Terms for Connection	14
Section E – The Connection Process	15
Section F – Accreditation	17
Section G – Adoption of Contestable Works	18
Section H – Planning Permission and Land Rights	21
Section I – Arrangements for Shared Connections	25
Section J – Charging arrangements	28
Section K – Governance and Complaints	29
Section L – Definitions and Acronyms	31
Appendix 1 – Contestability Boundaries for a Generation Spur Connection	35
Appendix 2 – Contestability Boundaries for a High Voltage Demand Customer	36
Appendix 3 – Contestability Boundaries for a Low Voltage Demand Customer	37
Appendix 4 – Contestability Boundary in a New Underground Supply	38
Appendix 5 – Contestability Boundary – New transformer on existing pole	39
Appendix 6 – Contestability Boundary – New two span spur plus transformer	40
Appendix 7 - High Level Process for Contestable Delivery of a Distribution Connection	41
Appendix 8 - Contestability Boundaries for Shared Connection Works to the Distribution System	43
Appendix 9 - High-Level Process for the Contestable Delivery of a Cluster	44

Section A – Introduction

1 The Introduction of Contestability

- 1.1 The principal objective of the Utility Regulator is set out in Article 12 of The Energy (Northern Ireland) Order 2003 (“Energy Order”) and it is to protect the interests of consumers of electricity supplied by authorised suppliers, wherever appropriate by promoting effective competition between persons engaged in, or in commercial activities connected with, the generation, transmission or supply of electricity.
- 1.2 Article 5 of the Energy Order requires the Utility Regulator to publish a Forward Work Programme and in the 2014-15 document the Utility Regulator set out plans for the introduction of contestability in new electricity connections in order to promote choice for customers and reduce both connection costs and timescales. The intention was to introduce contestability for all connections, including demand and generation connections, connections at all voltage levels and for both large and small-scale connections.
- 1.3 The Utility Regulator has issued the following papers in relation to the introduction of contestability in Northern Ireland:
- Contestability in Connections Call for Evidence, 9th September 2014 ¹
 - Contestability in Connections Consultation Paper, 2nd December 2014 ²
 - Contestability in Connections Proposed Next Steps Paper, 11th May 2015 ³
 - Contestability in Connections Decision Paper (“the Decision Paper”), 31st July 2015 ⁴

2 Contestability Guidelines

- 2.1 This document has been produced jointly by Northern Ireland Electricity Networks (“NIE Networks”) and SONI (jointly “the Licensees”) and it further defines and establishes the principles of contestability outlined in the Decision Paper.
- 2.2 A previous version, Version 2, was published on 31 May 2016 and contained information on contestability with regard to new transmission and distribution connections, although transmission contestability was not available at that time. It covered the initial phase of contestability - new connections to the Distribution System with capacities of 5 MW and greater.
- 2.3 The Licensees have now agreed that the Guidelines should be split into two documents, one covering new distribution connections and one covering new transmission connections. This document is the first version specific to new distribution connections and reflects that as from 28 March 2018 contestability also

¹ [Contestability in Connections Call for Evidence, 9th September 2014](#)

² [Contestability in Connections Consultation Paper, 2nd December 2014](#)

³ [Contestability in Connections Proposed Next Steps Paper, 11th May 2015](#)

⁴ [Contestability in Connections Decision Paper \(“the Decision Paper”\), 31st July 2015](#)

applies to new connections to the Distribution System with capacities less than 5 MW.

- 2.4 The Guidelines covering new transmission connections can be found at [link].
- 2.5 This Section A provides general guidelines on how contestability works in electricity connections in Northern Ireland. The following sections provide more detail on how contestability works in new connections to the Distribution System.
- 2.6 The Guidelines is not a legally binding document.
- 2.7 This is an active document and it will be updated as the contestability arrangements evolve.

3 Contestability

- 3.1 Contestability is the process where an Independent Connection Provider (“ICP”) may undertake elements of the provision of a new connection to either the Transmission or Distribution System.
- 3.2 Should Contestable Works be installed by an ICP then, after successful Commissioning Tests and providing certain conditions are met:
 - (i) the ownership of the Contestable Works will be transferred to NIE Networks; and
 - (ii) NIE Networks will assume operational responsibility for Contestable Works on the Distribution System and SONI will assume operational responsibility for Contestable Works the Transmission System.

4 NIE Networks and SONI - Roles and Responsibilities

- 4.1 SONI is the Transmission System Operator (“TSO”) in Northern Ireland and is regulated by means of a Transmission Licence. The licence requires SONI to plan, operate and co-ordinate/direct the flow of electricity onto and over the Transmission System.
- 4.2 In accordance with Condition 25 of the licence, SONI is required to offer terms to customers for connection to the Transmission System. SONI is responsible for defining the connection arrangements, including any Reinforcements Works required to facilitate connection to the Transmission System.
- 4.3 SONI is also responsible for:
 - (i) ensuring that new connections to the Transmission System are constructed in accordance with the terms set out in the accepted connection offer letter;
 - (ii) ensuring that customers’ equipment connected to, or to be connected to, the Transmission System complies with the Grid Code; and
 - (iii) planning, designing and obtaining consents for any Reinforcement Works on the Transmission System required to facilitate connections to the Distribution System.

-
- 4.4 NIE Networks owns both the Transmission and Distribution Systems in Northern Ireland and is regulated by means of a Transmission Licence and a Distribution Licence. NIE Networks therefore acts as a Distribution Network Operator (“DNO”) and a Transmission Owner (“TO”). The licences require NIE Networks to:
- (i) plan, develop, construct, maintain and operate the Distribution System; and
 - (ii) develop, construct and maintain the Transmission System.
- 4.5 NIE Networks is subject to a statutory duty to connect and is required to offer terms to customers for connection to the Distribution System in accordance with Condition 30 of the Distribution Licence. NIE Networks is responsible for defining the connection arrangements and identifying any Reinforcements Works on the Distribution System required to facilitate connection to the Distribution System.
- 4.6 NIE Networks is also responsible for:
- (i) ensuring that new connections to the Distribution System are constructed in accordance with the terms referred to in the Terms Letter; and
 - (ii) ensuring that customers’ equipment connected to, or to be connected to, the Distribution System complies with the Distribution Code.
- 4.7 Note that in this document where the Licensees believe it is necessary to differentiate between the obligations or views of the Transmission System Operator (“TSO”), the Transmission Owner (“TO”) or the Distribution Network Owner (“DNO”) the appropriate term is used.

5 The Transmission Interface Arrangements

- 5.1 The arrangements between SONI and NIE Networks, with respect to the co-ordination of their respective licence obligations, are set out in the Transmission Interface Arrangements (“TIA”), required by Condition 18 of the SONI Licence and Condition 17 of the NIE Networks Transmission Licence. The TIA also sets out obligations on NIE Networks in its role as TO and DNO and SONI as TSO relating to distribution connections requiring works to be carried out on the Transmission System.
- 5.2 These arrangements have been in place since the start of the Single Electricity Market (“SEM”) in 2007 and were updated on 1 May 2014 to reflect the transfer of the transmission planning function from NIE Networks to SONI and again on 1 September 2016 to take account of contestability requirements.

6 Obligations under the Electricity Order

- 6.1 SONI and NIE Networks are required under Article 12 of The Electricity (Northern Ireland) Order 1992 (“Electricity Order”) to develop and maintain efficient, co-ordinated and economical electricity Transmission and Distribution Systems.
- 6.2 SONI’s and NIE Networks’ obligations under the Electricity Order are not diminished where an ICP undertakes Contestable Works and therefore the Licensees must ensure that any modifications or expansions to the Transmission and Distribution Systems are efficient, co-ordinated and economical. It is essential

that new connections are constructed to the specification and in the location that are consistent with these requirements.

7 Offers for Connection to Contestable Works

7.1 NIE Networks has a statutory duty to connect, described in paragraph 4.5 of this section A, and has a statutory duty to develop an efficient, co-ordinated and economical Distribution System, described in paragraph 6.1 of this Section A. NIE Networks must also offer terms for connection which comply with its licence obligations and its Statement of Charges. All of these obligations must be reconciled where the preferred option is to offer terms for connection to Contestable Works being undertaken by an ICP which are not complete at the time of making the offer and, therefore, have not been adopted by NIE Networks.

7.2 An example of this is a connection application from a person requiring connection in the vicinity of electricity infrastructure which is still being delivered by an ICP. Since NIE Networks has no control over the delivery of that infrastructure it cannot be responsible for any delays in connecting another party to that infrastructure. Connection offers will have to reflect that general principle.

8 Capitalised Terms

8.1 The meanings of terms which are capitalised can be found in Section L, Definitions and Acronyms.

9 Other Relevant Documents

9.1 In addition to the documents previously referenced, this document may need to be read in conjunction with a number of other documents including the following:

[The Distribution Code](#)

[Statement of Charges for connection to the Northern Ireland Electricity Distribution System](#)

[The Grid Code](#)

[The Transmission Connection Charging Methodology Statement](#)

[The Transmission Interface Agreement between SONI and NIE Networks](#)

10 Structure of the Guidelines

10.1 This paper is made up of the following sections:

- Section B describes transitional arrangements and the current scope of contestability,
- Sections C, D and E describe the processes for connection applications, connection offers, acceptance of offers and the connection process. Except where otherwise stated, these sections apply to single user connections,
- Section F covers accreditation requirements for providers of Contestable Works,

- Sections G and H set out the guidelines for transfer of ownership, consenting and wayleaves for Contestable Works,
- Section I covers shared Connection Works,
- Sections J and K deal with charging arrangements and governance,
- Section L provides definitions and acronyms, and
- Appendices 1 - 9 provide illustrations of contestability boundaries and the high-level process for contestable delivery of new distribution connections.

Section B – Distribution Transitional Arrangements and the Scope of Contestability

1 General

- 1.1 Contestability is currently available for all new generation and demand connections to the Distribution System.
- 1.2 Where, prior to 28 March 2018, a customer received and accepted terms for a connection with a capacity of less than 5 MW, contestability is not available. NIE Networks processes a very large quantity of connections with capacities of less than 5 MW connections and it is therefore not possible to modify accepted terms to allow contestability.
- 1.3 Where, prior to 28 March 2018, a customer applied for a connection and received, but not yet accepted, terms for connection the customer may request that NIE Networks issues a Terms Letter after 28 March 2018 containing both a Full Works Option and a Non-Contestable Works Option. The Terms Letter will be issued within three months of the date of the request unless a longer period of time is approved by the Utility Regulator. Provided the original offer is still within its validity period at the time of applying for the subsequent offer, an additional fee will not be charged for processing this request and the request shall have no impact on the customer's connection queue position.
- 1.4 For the avoidance of doubt, where a customer applied for connection prior to 28 March 2018 and had not received terms for connection by 28 March 2018, the Terms Letter will contain both a Full Works Option and a Non-Contestable Works Option.
- 1.5 It should be noted that contestability will have no impact on the connection queue. The customer's position in the queue will be determined by the time of receipt of a valid connection application, complete in all respects, and the customer will hold that position unless the Terms Letter is not accepted within its validity period or the customer withdraws the application.

2 Non-Contestable and Contestable Works

- 2.1 Connection Works required for a new connection to the Distribution System consist of Non-Contestable Works and Contestable Works.
- 2.2 Non-Contestable Works are those Connection Works which may only be carried out by either NIE Networks or SONI (and 'Non-Contestable' should be interpreted accordingly).
- 2.3 Contestable Works are those Connection Works which can be carried out by a party other than NIE Networks and SONI (and 'Contestable' should be interpreted accordingly).

3 The Decision Paper

-
- 3.1 Section 4 of the Decision Paper contains the Utility Regulator's decision on which activities are Contestable and which are Non-Contestable. Paragraphs 4 and 5 of this section provide additional details on these activities.
- 3.2 Diagrams showing examples of contestability boundaries can be found in the Appendices. These diagrams do not cover all possible connection designs but have been chosen to cover the more common designs and illustrate the principles to be applied.

4 Non-Contestable Works

- 4.1 The following paragraphs provide further detail on the scope of the Non-Contestable Works in a new connection to the Distribution System.
- 4.2 Definition of the Point of Connection and connection design ⁵
- 4.2.1 NIE Networks has defined responsibilities in relation to planning and developing the Distribution System in an efficient, economic and co-ordinated manner and therefore will have complete responsibility for determining the Points of Connection to the Distribution System.
- 4.2.2 The connection design will specify the configuration of the connection, from the Point of Connection on the Distribution System to the Connection Point. It will define the voltage level at which the connection is to be made and the type of connection (radial or meshed). It will include single line diagrams as well as protection, control and communication requirements. It details the functional requirements for the Connection Works.
- 4.3 Reinforcement Works
- 4.3.1 Reinforcing the Transmission and Distribution System is Non-Contestable as these works will have an impact on system security of supply and on customers connected to or using the network.
- 4.3.2 Reinforcement Works on the Transmission or Distribution Systems, although Non-Contestable, may be a requirement for the customer to connect. Therefore, the delivery of the Reinforcements Works will need to be factored into the connection delivery programme.
- 4.4 Determination of the Ownership Boundary
- 4.4.1 NIE Networks will determine the ownership boundary, which defines the point at which the assets that will remain in the ownership of the customer join to the Contestable Works, which will be adopted by NIE Networks. The ownership boundary is the Connection Point.
- 4.5 Working on the Distribution System and making the final connection to the system.

⁵ The design process comprises elements which are Non-Contestable and Contestable. Development of the high-level design of the Contestable Works is Non-Contestable whereas development of the detailed design of the Contestable Works is Contestable.

- 4.5.1 Works on the Distribution System are not open to contestability to ensure safety, system security and reliability. NIE Networks has complete responsibility for all works on the Distribution System.
 - 4.5.2 Modifications, Alterations and Diversions are therefore not open to contestability as they involve work on the Distribution System.
 - 4.5.3 Final connection of the Contestable Works to the Distribution System will be carried out by NIE Networks and is Non-Contestable.
- 4.6 Technical Specifications and Policies
- 4.6.1 The development of technical specifications and policies which specify NIE Networks' minimum requirements for all Contestable Works are Non-Contestable.
 - 4.6.2 They consist of specifications for plant and materials as well as best practises in relation to activities such as route selection, site selection, wayleaving and installation of plant.
 - 4.6.3 These technical specifications and policies are published on the NIE Networks ICP Portal which can be found [here](#).
 - 4.6.4 Also published on the NIE Networks' ICP Portal are lists of current suppliers and approved plant.
- 4.7 Protection and Control Systems
- 4.7.1 Design and installation of protection and control systems which relate exclusively to the Distribution System are Non-Contestable to ensure the integrity of the system.
 - 4.7.2 Certain elements of protection and control equipment will apply to the Distribution System and the customer's systems. In this case, the arrangements will be considered for each connection but, in general, protection equipment, current transformers and voltage transformers forming part of the Contestable Works can be provided contestably.
 - 4.7.3 Some protection and control systems may need to be manufacturer specific to ensure interoperability with protection and control systems on the Distribution System.
- 4.8 Metering
- 4.8.1 Metering is Non-Contestable as it is essential that the measurement of the consumption and generation of electricity is independent, accurate and transparent. NIE Networks will continue to purchase, install and calibrate meters and NIE Networks will continue to be the meter registrant.
- 4.9 Event recorders

4.9.1 Event recorders may be installed by NIE Networks or SONI as required. All works relating to event recorders are Non-Contestable.

4.10 Communication

4.10.1 Communication via SCADA is Non-Contestable as it is critical to the security and performance of real time systems. NIE Networks or SONI will continue to purchase, install, test and maintain communications equipment required for a connection. This will include, but is not limited to, any uninterruptible power supply, remote terminal unit and cable termination cabinet that may be required.

4.11 Review of Contestable Works

4.11.1 Throughout the connection process NIE Networks will carry out reviews and/or inspections of the Contestable Works⁶ against the relevant technical specifications and policies.

4.11.2 The review and inspection process will include the review and/or inspection of the following aspects of the Contestable Works:

- (i) Reviewing the customer's route and site selection against the high-level design and relevant technical specifications and policies;
- (ii) Reviewing the customer's detailed design against the functional requirements and relevant technical specifications and policies;
- (iii) Inspection of any plant, materials and installation during the construction phase to ensure they meet the detailed design and relevant technical specifications and policies. NIE Networks will have unrestricted rights of inspection with respect to all Contestable Works under construction (subject to health & safety requirements and access protocols);
- (iv) Monitoring progress of the Contestable Works⁷ against agreed timelines to ensure that:
 - NIE Networks' obligations under the Electricity Order to develop the Distribution System in an efficient, co-ordinated and economical manner is not hindered by the delivery of the Contestable Works;
 - no other customer is disadvantaged by the progression of the delivery of Contestable Works and, in addition to the duties under the Electricity Order, allow NIE Networks to fulfil its obligations under the licence;

⁶ In the case of clusters, SONI may carry out reviews and inspections of certain transmission designs and equipment.

⁷ SONI will perform these functions with regard to cluster transmission works

- the delivery of the Non-Contestable Works is co-ordinated with the delivery of the Contestable Works;
 - monitoring and inspections are carried out in a timely and efficient manner; and
 - the delivery of sole-use Contestable and Non-Contestable Works are co-ordinated with the delivery of Shared Contestable Works being delivered by the Lead Developer.
- (v) Appraising changes proposed by the customer and considering consequential changes to the functional requirements, customer's detailed design in adherence with relevant technical specifications and policies;
- (vi) Appraising changes proposed by the customer and approving consequential changes to the agreed timelines for the connection delivery; and
- (vii) Witnessing Pre-Commissioning Tests to ensure relevant technical specifications and policies are adhered to and being satisfied that final connection can proceed.

4.11.3 Throughout the review and inspection process NIE Networks will provide relevant feedback to the customer.

4.11.4 NIE Networks may increase or decrease the level of inspection and review of the Contestable Works based on the results of the inspections.

4.11.5 The customer will be responsible for any changes to the Contestable Works to meet the relevant technical specifications and policies as requested by the Licensee.

4.12 Handover and acceptance of Contestable Works

4.12.1 NIE Networks has complete responsibility for:

- (i) the decision to accept ownership and operational responsibilities of Contestable Works on the Distribution System; and
- (ii) the decision to accept ownership of Contestable Works on the Transmission System.

4.12.2 SONI has complete responsibility for the decision to accept operational responsibility of the Contestable Works on the Transmission System.

4.13 Commissioning Tests

4.13.1 Commissioning Tests on Contestable and Non-Contestable Works following final connection is Non-Contestable to ensure safety, system security and reliability.

4.13.2 NIE Networks will specify the testing programme and any customer assistance required.

4.14 Grid Code and Distribution Code

4.14.1 For the avoidance of doubt, SONI will continue to be responsible for ensuring Grid Code compliance and NIE Networks will continue to be responsible for ensuring Distribution Code compliance.

5 Contestable Works

5.1 The following paragraphs provide further detail on the activities which may be undertaken contestably in a new connection. As stated in Section D, the Offer and Offer Acceptance Process, if the customer wishes to undertake some of the Contestable Works then all the Contestable Works must be undertaken.

5.2 Exceptions

5.2.1 In reading this section it must be remembered that:

- (i) pre-construction work for Cluster Infrastructure; and
- (ii) construction work for Cluster Infrastructure where there is a contribution from the Northern Ireland customer base,

are both Non-Contestable.

5.3 Design, Procurement and Construction

5.3.1 Design, procurement and construction/installation of:

- (i) proposed circuit routes;
- (ii) the customer's protection and control systems;
- (iii) overhead line support positions;
- (iv) overhead line support types;
- (v) cable alignment;
- (vi) substation layouts;
- (vii) plant, cables and overhead lines;
- (viii) CTs, VTs and protection equipment which form part of the Contestable Works;
- (ix) design fault ratings; and
- (x) Optical fibre cables, either integral with overhead conductors or laid next to underground power cables.

5.4 Route and Site Selection

5.4.1 Selection of circuit route and site selection is Contestable but the NIE Networks' technical specifications and policies will apply.

5.4.2 The Licensees will also specify requirements to ensure that the development of distribution and transmission infrastructure is carried out in an efficient and co-ordinated manner. The Licensees do not intend to place any undue constraints on the development of viable routes and site selection but where such routes and sites can be modified to avoid unduly constraining other network developments then that should be the case.

5.5 Site Acquisition

5.5.1 Land purchase required for the Contestable Works is Contestable.

5.5.2 However, the Licensees reserve the right to purchase land for Contestable Works if the Licensee is also developing distribution or transmission infrastructure in the area to allow for a more co-ordinated approach with stakeholders and communities.

5.6 Attaining Planning Permission, Wayleaves and Easements

5.6.1 Securing planning permission, wayleaves and Easements are contestable activities. However, the Licensees reserve the right to apply for planning permission, wayleaves and Easements for Contestable Works if a Licensee is also developing distribution or transmission infrastructure in the area to allow for a more co-ordinated approach with stakeholders and communities.

5.6.2 Where a Licensee applies for planning permission wayleaves and/or Easements under these circumstances then this will not preclude contestability for the other aspects of the connection. To clarify, the Licensees only see this situation arising in exceptional circumstances.

5.7 Pre-Commissioning Tests

5.7.1 The customer shall be responsible for all Pre-Commissioning Tests on the Contestable Works.

5.7.2 Pre-Commissioning Tests are the testing of the Contestable Works carried out prior to and in readiness for final connection, energisation and Commissioning Tests.

5.7.3 Requirements for witnessing any Pre-Commissioning Tests shall be specified in the Terms Letter.

5.7.4 The customer shall provide certification to the Licensees detailing all the Pre-Commissioning Tests that have been carried out on the Contestable Works along with a statement of full conformance with the Licensees' relevant technical specifications and policies. Pre-Commissioning Tests must be satisfactorily completed prior to final connection.

Section C – The Application Process

1 The Application Process

- 1.1 A customer wishing to receive terms for connection to the Transmission System should apply to SONI and if a connection is sought to the Distribution System then an application should be made to NIE Networks.
- 1.2 Both SONI and NIE Networks will provide advice if the customer is unsure whether to make a transmission or distribution application.
- 1.3 Information on how to apply for a connection to the Distribution and Transmission Systems can be found on the NIE Networks ⁸ and SONI ⁹ websites respectively. The associated application forms are also available to download and these set out what information needs to be provided in order to receive a connection. An application fee may apply.
- 1.4 As discussed in Section A, NIE Networks and SONI have different obligations under their licences and under the Electricity Order regarding connections. Consequently, the process of applying for connection varies depending on which system the connection relates to.

Application for connection to the Distribution System

- 1.5 An application for connection is treated as a notice under Article 20(1) of the Electricity Order.
- 1.6 Applications for connection can be made online [here](#).
- 1.7 After receipt of an application for connection containing all such information as NIE Networks may reasonably require it shall issue terms for connection, unless it is exempt from doing so under Article 21 of the Electricity Order.

⁸ Information on how to apply for a connection to the Distribution System can be found [here](#).

⁹ Information on how to apply for a connection to the Transmission System can be found [here](#).

Section D – The Issue and Acceptance of Terms for Connection

1 The Issue of Terms for Connection

1.1 Following assessment of the connection application and providing it contains all information reasonably required by NIE Networks a Terms Letter will be issued containing two options for the Connection Works as described below. These options are mutually exclusive and only one can be accepted:

- Option 1 is for NIE Networks to undertake all of the Connection Works and the Reinforcement Works, if any, and is known as the Full Works Option.
- Option 2 is for NIE Networks to undertake only the Non-Contestable Works and the Reinforcement Works, if any, and is known as the Non-Contestable Works Option.

1.2 The Terms Letter will be accompanied by a Functional Specification and a Quotation Summary.

1.2.1 The Functional Specification will fully describe the Contestable Works and the Non-Contestable Works; and

1.2.2 The Quotation Summary will set out the charges payable by the customer depending on which option is chosen. The appropriate charges for operation and maintenance will also be confirmed, if applicable.

2 DNO preferred connection method

2.1 NIE Networks would like to clarify that there is the potential for NIE Networks to require a connection asset to be delivered at a higher functional specification than the least cost technically acceptable connection (i.e. above the minimum standard required for the connection). As noted in Section A, paragraph 6.2, the obligation to develop the Distribution System in an efficient, co-ordinated and economical way must not be undermined by the introduction of contestability.

2.2 It does mean however, that NIE Networks will need to put in place a process with the Utility Regulator to recover the incremental cost of any such preferred connection method for this to be transferred to the customer delivering the Contestable Works.

3 Acceptance of Terms

3.1 To accept either the Full Works Option or the Non-Contestable Works Option as set out in the Terms Letter the customer must complete and sign the Acceptance of Terms form relevant to the chosen option. It should be noted that the Terms Letter will have two “Acceptance of Terms” forms enclosed and that only one can be signed and returned by the customer to confirm which option has been selected.

3.2 The Terms Letter is capable of acceptance for a period of 90 days from its date of issue and will cease to be valid after that date.

Section E – The Connection Process

1 General

- 1.1 This section provides guidelines on the processes to be followed after acceptance of the Terms Letter. It should be noted that it only highlights matters which are specific to contestability.
- 1.2 It is assumed in this section that the customer has selected the Non-Contestable Works Option in the Terms Letter so that the customer or an ICP shall undertake the Contestable Works.
- 1.3 Additional information in relation to the rights and responsibilities of both the customer and NIE Networks when undertaking the Contestable Works and Non-Contestable Works is given in the 'Technical Terms for Connection', 'General Terms for Connection Works' and 'Contestable Connection Terms and Conditions' (should the Contestable Works be carried out by the customer or an ICP) which accompany the Terms Letter.

2 Technical Information

- 2.1 Upon acceptance of the Terms Letter the customer will have confirmation of the following technical information:
 - (i) The Connection Works and Reinforcement Works;
 - (ii) The Non-Contestable Works;
 - (iii) The Contestable Works;
 - (iv) The Point of Connection; and
 - (v) The Connection Point.
- 2.2 NIE Networks will make available to the customer all necessary high-level designs, specifications, functional requirements, policies and information on approved suppliers and equipment.

3 Roles and Responsibilities

- 3.1 Appendix 7 sets out a high-level flow chart showing an end-to-end distribution connection. The flow chart illustrates a connection where:
 - (i) The customer has agreed to deliver all the Contestable Works; and
 - (ii) The distribution connection does not require any transmission works.
- 3.2 Liaison between NIE Networks and the customer is imperative, particularly during the early development of contestability. Of particular importance are:
 - (i) Development of pre-construction and construction programmes;
 - (ii) Development by the customer of detailed designs which require to be reviewed by NIE Networks;
 - (iii) Adoption - this is covered in detail in section G;

- (iv) The acquisition of consents, wayleaves and Easements. This is discussed in detail in section H of this document;
 - (v) Construction (covered in a number of sections in this document):
 - regular information exchanges on progress
 - construction plans,
 - monitoring, inspection, audit,
 - Pre-Commissioning Tests,
 - handover of operational control for energisation and Commissioning Tests, and
 - adoption.
- 3.3 Where milestones have been set out in the Terms Letter in relation to the Contestable Works, or are subsequently included in the pre-construction programme or construction programme, and these milestones are not met, NIE Networks shall have the right to change the terms of the Terms Letter. This is to:
- 3.3.1 ensure that the obligation under the Electricity Order to develop the relevant system in an efficient, co-ordinated and economical manner is not hindered by the contestable delivery of connection assets; and
 - 3.3.2 ensure that no other customer is disadvantaged by the progression of the delivery of the Contestable Works and, in addition to the duties under the Electricity Order, allow NIE Networks to fulfil its obligations under the licence.

Section F – Accreditation

1 Accreditation and notification of proposed ICPs

- 1.1 ICPs must hold relevant accreditation for specific activities undertaken under the National Electricity Registration Scheme (NERS) operated by Lloyd's Register in Northern Ireland.
- 1.2 Where the Contestable Works entail an activity which is within the scope of the Lloyd's scheme then accreditation is required to carry out that activity.
- 1.3 Details of the ICP(s) which the customer proposes to use shall be submitted to the NIE Networks in advance of the Contestable Works commencing.
- 1.4 Where the Contestable Works have been installed by an ICP then failure to operate under the NERS will affect Commissioning Tests and adoption of the assets by NIE Networks – refer to Section G for further details.

Section G – Adoption of Contestable Works

1 Adoption Agreement

- 1.1 Where the customer (or the customer's appointed ICP) wishes to provide the Contestable Works then the customer and/or their appointed ICP (as the circumstances require) must enter into an Adoption Agreement with NIE Networks which will set out the terms and conditions upon which NIE Networks will adopt (i.e. assume ownership) of the assets constructed by the ICP and/or customer.
- 1.2 Template Adoption Agreements are intended to be used by NIE Networks. In order to ensure consistency of approach NIE Networks does not believe the template Adoption Agreement should be the subject of negotiation with the customer and/or ICP. However, where the circumstances of the Contestable Works are complex and require supplementary terms (as may be the case with Shared Contestable Works) then NIE Networks and the customer / ICP may agree such additional terms as may be required.
- 1.3 A template tri-partite Adoption Agreement is available for review on the ICP Portal. An Adoption Agreement (whether in the form of the template agreement or with supplementary terms agreed by NIE Networks) must be signed by the customer and/or the ICP (as the circumstances require) and returned to NIE Networks prior to the ICP commencing works. Should a bi-partite Adoption Agreement be required this will be in substantially the same terms as the template tri-partite Adoption Agreement.
- 1.4 If there is any inconsistency between the terms of the Terms Letter or the Adoption Agreement and this Section G the terms of the Terms Letter and/or Adoption Agreement shall take priority. These Guidelines are only intended as a summary of those documents and it is the responsibility of the customer and/or ICP to take their own advice in relation to them.

2 Conditions Precedent

- 2.1 Adoption by NIE Networks of the assets constructed by the ICP is subject to the satisfaction of a number of conditions including (without limitation) :
 - (i) The ICP must hold relevant accreditation for the works constructed under the National Electricity Registration Scheme (NERS) operated by Lloyds Register in Northern Ireland;
 - (ii) The ICP has constructed the asset in accordance with the documents provided by NIE Networks relating to the design, specification and standard of construction of the asset using materials and workmanship required by NIE Networks in accordance with the Section E (The Connection Process);
 - (iii) All obligations contained in the Terms Letter, any documents referred to therein, and the Adoption Agreement have been satisfactorily performed;
 - (iv) NIE Networks has signed a Completion Certificate confirming that the Pre-Commissioning Tests and Commissioning Tests required by NIE Networks in accordance with Section E (the Connection Process) have been carried out to NIE Networks' satisfaction;

-
- (v) No Major Defects exist;
 - (vi) The ICP has transferred to NIE Networks all documentation relating to the asset, including without limitation as built drawings, safety documentation and manufacturer's warranties, in accordance with Section E (the Connection Process) together with such intellectual property rights as are required by NIE Networks to use the documentation;
 - (vii) The ICP has obtained all necessary legal consents (including without limitation wayleaves, Easements, leases, planning permission, street works consent and Article 40 consent) for the construction and retention of the asset as required by NIE Networks in accordance with the Consents and Wayleaves Guidelines and will transfer these legal consents to NIE Networks as may be required; and
 - (viii) The ICP and/or customer, as the case may be, has paid all costs due to NIE Networks applicable to the Non-Contestable Works Option.
- 2.2 Where the ICP has used all reasonable endeavours to meet the conditions precedent but Minor Defects exist, NIE Networks may, in its sole discretion, still adopt the Contestable Works provided that:
- (i) A Minor Defects list is agreed by the ICP and NIE Networks;
 - (ii) The ICP agrees to rectify all Minor Defects on the list within three months from the date of adoption, or another period if agreed in writing; and
 - (iii) The ICP shall compensate NIE Networks for all costs it incurs.

3 ICP Warranties

- 3.1 In order for NIE Networks to satisfy itself that it is assuming ownership of assets which are unencumbered by a potential financial liability it will be necessary for the counter-party to the Adoption Agreement to provide a number of warranties in relation to the assets being adopted, including (without limitation):
- (i) That it is the sole legal owner of the works and they are not subject to any encumbrance;
 - (ii) That it has full authority to transfer ownership; and
 - (iii) That the Contestable Assets are not subject to any encumbrance.

4 Defects Correction

- 4.1 The customer and/or ICP shall compensate NIE Networks for all costs incurred by NIE Networks in remedying Major Defects which appear within 36 months from the date of adoption.
- 4.2 Major Defect correction may only be performed by NIE Networks except where NIE Networks elects to require the customer and/or ICP to carry out correction of the Major Defect by notifying the customer and/or ICP of the Major Defect, the timeframe in which the Major Defect must be rectified, and any other relevant information.

4.3 Where the customer and/or ICP:

- (i) fail to respond to NIE Networks' notification; or
- (ii) do not remedy the Major Defect,

NIE Networks shall undertake correction of the Major Defect and the customer and/or ICP shall compensate NIE Networks for all costs incurred.

5 Liability for Breach

- 5.1 Liability provisions are contained in the Contestable Connection Offer Terms and Conditions and Adoption Agreement.

6 Construction and Commissioning Tests

- 6.1 The Contestable Works Terms and Conditions confirms the process for NIE Networks reviewing the design of the works and witnessing the construction of the asset. NIE Networks shall be entitled to identify any concerns during construction by the ICP and/or customer and require the ICP and/or customer to undertake remedial works. The process for undertaking Pre-Commissioning Tests and the holding of a pre-adoption meeting (if required) is described in the Adoption Agreement. When NIE Networks is satisfied that the requirements for adoption have been met it shall sign a Completion Certificate which shall confirm the date on which the asset is adopted by NIE Networks.

7 Additional Protection for NIE Networks

- 7.1 The obligations on the ICP and/or customer with respect to insurance are set out in the Contestable Works Terms and Conditions.
- 7.2 To the extent that any security or guarantee may be required by NIE Networks in relation to the Contestable Works this shall be determined on a case by case basis and will be set out in the Terms Letter if required. The Adoption Agreement shall have such appendices or schedules attached as may be required for the parties to meet their obligations described in the agreement.

Section H – Planning Permission and Land Rights

1 Background

- 1.1 In the Decision Paper the Utility Regulator stated (section 4.2.2) that the following activities would be deemed to be Contestable:
- (i) Site Acquisition;
 - (ii) Planning Permission; and
 - (iii) Wayleaves.
- 1.2 A customer may therefore carry out these activities to the extent that they are required for a new connection to be made to the Distribution System. These Guidelines describe the legal processes required by NIE Networks in order to ensure that where an ICP installs new equipment as a part of Contestable Works, and such equipment is adopted, NIE Networks will have those unencumbered legal rights it requires for the future operation, maintenance and repair of the equipment.

2 Site Acquisition

- 2.1 NIE Networks requires that all sites on which substations are to be located are either held by it in freehold or under long term lease. A template lease shall be provided by NIE Networks for Contestable substations which shall incorporate those lease terms that NIE Networks requires.
- 2.2 The customer shall determine the position of the site and shall agree in principle with the relevant landowners the terms for acquiring or leasing the site. The customer or ICP, as appropriate, shall then submit details of the proposed site with the design proposal ('the Design') to NIE Networks for review along with the relevant acquisition or lease terms and landowner information.
- 2.3 Any premium or payment to be paid for the acquisition of freehold title or under the terms of a lease shall be paid by the ICP to the landowner. NIE Networks shall only be liable for nominal annual payments to the landowner which fall due after the connection has been adopted by NIE Networks.
- 2.4 Following review of the design by NIE Networks, the customer shall have the legal documentation completed in accordance with paragraph 6.3 below.

3 Planning Permission

- 3.1 The customer will be responsible for all aspects of obtaining planning permission for any substation or electrical circuit and any other asset associated with Contestable Works where such planning permission is required. The customer shall provide confirmation of any planning permission being sought when submitting the design and provide an update to NIE Networks when planning permission has been obtained together with a copy of the planning permission and any associated conditions. Where any planning application is refused and is the subject of an appeal the customer shall provide such information as may be requested by NIE Networks regarding the conduct of the appeal.
-

- 3.2 The customer shall also be responsible for obtaining the following statutory consents:
- (i) Any consent required by the relevant statutory authority with respect to the customer undertaking works in a public street or road;
 - (ii) The consent required to be given by the relevant statutory authority pursuant to Article 40 of the Electricity (NI) Order 1992;
 - (iii) Any 'Necessary Wayleave' or Easement to be obtained by vesting under the Electricity (NI) Order 1992 except in circumstances where only NIE Networks or SONI may apply for such consents; and
 - (iv) Any other statutory consent which may be necessary to permit construction and retention of the Contestable Works.

4 Wayleaves and Easements

4.1 A 'wayleave' is a contractual licence granted by a landowner permitting retention of equipment subject to certain terms. An annual rent is payable by NIE Networks in consideration for the wayleave for so long as the wayleave remains in force. An 'Easement' grants a permanent right of retention subject to payment of an initial lump sum. There are certain circumstances in which NIE Networks will require an Easement and in these circumstances a Wayleave will not be appropriate. Both documents are legal documents but the proposed process for an ICP obtaining each document differs and is described below.

4.2 Wayleaves

4.2.1 A template Wayleave Agreement shall be provided by NIE Networks to govern the relationship between NIE Networks and the landowner post adoption of the equipment (e.g. for retention, access, maintenance and replacement).

4.2.2 Where the application of a Wayleave Agreement has been agreed by NIE Networks as part of the 'Design' (as opposed to the application of an 'Easement'), the customer will prepare the required Wayleave Agreement for the benefit of NIE Networks and in the standard form provided.

4.2.3 The customer shall make contact directly with the landowner to complete the required Wayleave Agreement. The customer shall secure the signature of the landowner on the Wayleave Agreement and shall then forward it to the nominated NIE Networks Wayleave Officer for 'sign-off'. When providing the signed Wayleave Agreement, the customer shall confirm that the content of the Wayleave Agreement has been fully explained to the relevant landowner and that it has been freely signed by the landowner.

4.2.4 After the Contestable Works have been adopted by NIE Networks then NIE Networks shall be responsible for payment of the annual wayleave rent to the landowner.

- 4.2.5 If a voluntary wayleave cannot be obtained by the customer it shall be responsible for securing a 'Necessary Wayleave' under the Electricity (NI) Order 1992 to the extent that it is able to do so.
- 4.2.6 The Wayleave Agreement shall not permit construction or installation of the Contestable Works. The customer shall obtain a separate agreement with the landowner in accordance with clause 5 below.

4.3 Easements

- 4.3.1 In certain circumstances NIE Networks may determine that an Easement will be required where termination of a voluntary wayleave by the landowner may expose NIE Networks (as the eventual asset owner) to unacceptable technical or financial risk. NIE Networks will be at liberty to require an Easement notwithstanding that the customer has proposed a wayleave as part of the Design proposal.
- 4.3.2 A template 'Grant of Easement' document shall be provided by NIE Networks to govern the relationship between NIE Networks and the landowner post adoption of the equipment (e.g. for retention, access, maintenance and replacement).
- 4.3.3 The lump sum payment payable under an Easement shall be payable by the customer to the landowner.
- 4.3.4 The customer shall make contact directly with the landowner to discuss the terms of the required Grant of Easement.
- 4.3.5 Once the customer has reached agreement in principle with the landowner, the customer shall have the legal documentation completed in accordance with paragraph 6.3 below.

5 Construction and Installation Agreement

- 5.1 The customer must enter into an agreement with the landowner(s) for the construction/installation of the required equipment. This agreement must confirm that liability for matters such as reinstatement and damage arising out of the construction stage, including any actions required for compliance with planning conditions, shall rest with the customer and not with NIE Networks. The installation agreement shall be between the customer and the landowner – NIE Networks will not be a party to this agreement nor will it accept any liability for damage or loss that may be suffered by the landowner during the installation of the equipment upon their land.
- 5.2 The terms of the agreement between the customer and the landowner will not be approved by NIE Networks but evidence that this agreement is in place must be provided.

6 Completion of Legal Documents

- 6.1 At the point where agreement has been reached in principle between the customer and the landowner regarding the obtaining of freehold title or the granting of a

lease or Easement, it will be necessary for the customer and the landowner to instruct their legal representatives to complete the legal documentation so that it can be registered against the title of the landowner. Given that the transfer of title document, lease or Easement will govern the relationship between NIE Networks and the landowner post adoption of the equipment (e.g. for retention, access, maintenance and replacement), it is important that NIE Networks (as the eventual asset owner) has agreed to any variations in terms from those that are contained in the template documentation initially provided to the customer.

- 6.2 Recognising that completion of the transfer of title, lease or Easement may involve the legal representatives of the customer, the landowner and NIE Networks the process described in paragraph 6.3 below is proposed with a view to an efficient and timely completion of legalities.
- 6.3 The customer shall instruct its legal representative who will liaise with NIE Networks' internal legal representative in relation to any variation of the NIE Networks template documents. Once any amendments to the template document have been agreed by NIE Networks' internal legal representative and the Lease or Easement has been executed by the landowner, the customer's legal advisor shall forward the document (together with a solicitor's Certificate of Title from the customer's legal advisor) to NIE Networks' legal advisor for approval and execution by NIE Networks. Once the lease or Easement has been executed by NIE Networks, it will be registered by NIE Networks' external legal representative. The customer shall pay the costs of NIE Networks' external legal representative including the cost of registration.
- 6.4 If the customer chooses to start installation works prior to land rights agreements being secured, the customer must satisfy themselves that they will be able to conclude these agreements with the landowners in sufficient time to allow the adoption of the equipment by NIE Networks within the required timeframe. Where any equipment is to be held under transfer of title, lease or Easement and such documentation has not been executed by both the landowner and NIE Networks, NIE Networks will not adopt the equipment. Furthermore, the customer shall continue to remain liable to NIE Networks in the event that the registration of a transfer of title, lease or Easement does not proceed due to the ability of the landowner to grant the transfer of title, lease or Easement becoming compromised prior to completion of the registration.
- 6.5 The above arrangements are consistent with the "Land Rights Guide" which can be downloaded from the ICP Portal [here](#).

Section I – Arrangements for Shared Connections

1 General Principles Relating to Contestability on Shared Connection Works

- 1.1 This section sets out the general principles relating to contestability on shared connections - connections where some of the Connection Works will be used by more than one customer.
- 1.2 Appendix 9 sets out a high-level flow chart showing the end-to-end process for a cluster. The flow chart focuses on the interaction between Customers, Lead Developers and the Licensees and, for simplicity, does not go into detail on the interactions between the Licensees. It illustrates a connection where:
- (i) All distribution customers agree to deliver their Unique Contestable Works contestably and do so themselves (using an ICP); and
 - (ii) All distribution customers agree to appoint a Lead Developer to deliver the Shared Contestable Works (using an ICP).
- 1.3 It is important to emphasise that these processes have not yet been tested and the contractual framework is still under development. There is a considerable amount of uncertainty in this process relating to, for example:
- (i) The development of the cluster and the agreement of the need for the cluster with the UR, sometimes happening prior to the first connection application;
 - (ii) The time interval between connection applications;
 - (iii) The time taken to appoint the Lead Developer;
 - (iv) The emergence of a late connection application after the appointment of the Lead Developer; and
 - (v) The withdrawal of a connectee after the appointment of the Lead Developer.
- 1.4 Under these circumstances the Connection Works will consist of:
- (i) Unique Non-Contestable Works;
 - (ii) Shared Non-Contestable Works;
 - (iii) Unique Contestable Works ; and
 - (iv) Shared Contestable Works.
- 1.5 The following principles apply to contestability on Connection Works which are shared:
- (i) Shared Contestable Works can only be undertaken contestably where the customers making use of the Shared Contestable Works unanimously appoint a Lead Developer to be responsible for delivering all of the Shared Contestable Works;
 - (ii) The Lead Developer must be one of the customers making use of the Connection Works;

-
- (iii) evidence must be provided to the DNO of the agreement reached between them;
 - (iv) the Lead Developer is the single point of contact interfacing with the DNO;
 - (v) if a contracted customer which has a Lead Developer terminates a connection offer prior to the Shared Contestable Works being complete the repercussions shall be dealt with under the agreement between that customer and the Lead Developer;
 - (vi) where a group of customers unanimously agree to shared assets being delivered contestably and appoint a Lead Developer to do so then the members of that group shall have no remedy against the DNO for any delay in delivery or failure by the Lead Developer to complete construction of the shared assets which would result in any commitments given by the DNO in a connection offer to that group member not being honoured;
 - (vii) if a Lead Developer or any of the other customers withdraw their agreement with the Lead Developer at any point, it will be the responsibility of the customers to resolve the situation;
 - (viii) in the event that the Lead Developer withdraws the remaining customers must reach agreement on the new Lead Developer and provide evidence of same to the DNO or the remaining customers may apply to the DNO for the DNO to undertake the Contestable Works, and
 - (ix) In the event that the Terms Letter , the pre-construction programme or the construction programme (each as defined in the Contestable Connection Terms and Conditions) provides for milestones in relation to the Contestable Works and such milestones are not met, NIE Networks shall have the right to change the terms of the Terms Letter. This is to:
 - ensure that the obligation under the Electricity Order to develop the relevant system in an efficient, co-ordinated and economical manner is not hindered by the contestable delivery of connection assets, and
 - ensure that no other customer is disadvantaged by the progression of the delivery of the Contestable Works and, in addition to the duties under the Electricity Order, allow NIE Networks to fulfil its obligations under the licence.
- 1.6 Where a Lead Developer has been appointed, the Lead Developer may also deliver its Unique Contestable Works. The other customers have a number of options regarding their Unique Contestable Works. They can
- (i) deliver the Unique Contestable Works themselves;
 - (ii) appoint the Lead Developer to deliver the Unique Contestable Works, where the Lead Developer agrees; or
 - (iii) agree that NIE Networks delivers the Unique Contestable Works.
- 1.7 The following sections provide examples of Shared Contestable Works setting out the principles which will be applied.

2 General Principles for Contestability on Cluster Infrastructure

-
- 2.1 Cluster Infrastructure typically comprises of transmission and distribution assets that are shared by customers connecting to the cluster i.e. generally the cluster transmission infrastructure from the Point of Connection to the Transmission System to the 33 kV switchboard in the cluster substation.
 - 2.2 Prior to the introduction of contestability in connections, the TSO and TO were always responsible for the transmission pre-construction works and the TO was always responsible for the transmission construction works.
 - 2.3 The pre-construction works of the Cluster Infrastructure includes activities such as route and site selection, design, land acquisition, securing planning permission, wayleaves and consents.
 - 2.4 The construction works of the Cluster Infrastructure includes activities such as detailed design, procurement and build.
 - 2.5 NIE Networks' Statement of Charges details the present cluster methodology and how the requirement for Cluster Infrastructure is identified by NIE Networks and SONI then charged by NIE Networks to customers connecting to the cluster.
 - 2.6 The present cluster methodology allows the financial risks of the delivery of the Cluster Infrastructure to be shared between the group of customers connecting to the cluster with the Northern Ireland customer base covering any differential between final costs and contributions. Regulatory approval is required for the Cluster Infrastructure to proceed.
 - 2.7 The present cluster methodology permits the development Cluster Infrastructure prior to customers making application to NIE Networks.
 - 2.8 The Decision Paper sets out rules regarding the delivery of Cluster Infrastructure contestably. This is the Licensees' interpretation of these decisions.
 - 2.8.1 The pre-construction works of Cluster Infrastructure is Non-Contestable whereas the construction of Cluster Infrastructure is Contestable.
 - 2.8.2 Where the Cluster Infrastructure is delivered contestably there would be no contribution from the Northern Ireland customer base, as set out in the Decision Paper.
 - 2.9 Where an asset is to be delivered contestably and NIE Networks issues a Terms Letter to a latecomer to connect to these assets in advance of their completion, that latecomer shall have no remedy against NIE Networks for the consequences of any delay in completion of these Contestable Works.

Section J – Charging arrangements

1 Charging Statements

- 1.1 Licence Condition 32 of the NIE Networks Distribution Licence and Licence Condition 30 of the SONI Transmission Licence require the preparation, and the Utility Regulator's approval, of statements setting out the basis upon which customers will be charged for connection to the Distribution and Transmission Systems.
- 1.2 These statements ("Statement of Charges") contain sufficient detail to enable a customer considering submitting a connection application to make a reasonable estimate of the charges to which it would become liable in respect of a connection to the Distribution and Transmission Systems.
- 1.3 Reference should be made to the relevant Statement of Charges as they contain useful information for customers considering the provision of Contestable Works.
- 1.4 Of particular relevance are:
 - (i) The derivation of operating and maintenance charges for Contestable Works;
 - (ii) Charges for carrying out various services associated with the Contestable Works; for example, review of the design and inspection of the assets to be adopted; and
 - (iii) Charges for Non-Contestable Works.

Section K – Governance and Complaints

1 Governance

- 1.1 As stated in the Section A, this document is essentially a user's guide and is not contractual.
- 1.2 As such, NIE Networks does not consider it to be appropriate to develop governance arrangements for this document. The contestability arrangements in Northern Ireland will not change by making a change to this document.
- 1.3 Accordingly, this document provides information on the contestability arrangements defined in other documents such as Terms Letters, Adoption Agreements and the Statement of Charges. Changes to other relevant documents will be reflected in changes to this document.

2 Complaints

- 2.1 Where a party requiring a connection or an ICP considers that NIE Networks is not providing a level of service which will promote competition in the provision of connections then NIE Networks will investigate the matter with the aim of finding a resolution and improving its policies and procedures. In order to provide a simple and effective means of resolving complaints NIE Networks proposes the following levels of escalation:
 - (i) Step 1 – A complaint should be initiated in writing with the local NIE Networks manager responsible for the type of connection sought. Specific details of the complaint should be given to allow a full investigation of the matter to be carried out. If the complaint has not been resolved within 10 working days then it may be referred to a senior manager.
 - (ii) Step 2 – A senior manager will review the complaint, the proposed means of dealing with it and any further information made available by the complainant.
 - (iii) Step 3 – If the complaint has not been resolved within 15 working days of being referred to the senior manager the complainant may confirm that they are unsatisfied with the action proposed by the senior manager and request in writing that the matter is referred to the Connections Director.
 - (iv) Step 4 – The Connections Director will undertake a final review of the complaint and confirm a final position within 20 working days of referral.
- 2.2 If steps (i) to (iv) above have been followed and the complaint remains unresolved then the complainant should consider the use of an independent arbitrator or mediator to investigate the complaint and propose a resolution. If the complaint is of a technical nature then the appointment of an arbitrator or mediator nominated by the Chartered Institute of Arbitrators or President of the Institution of Engineering and Technology may be appropriate. Where NIE Networks agrees that the appointment of an independent arbitrator or mediator is reasonable and the complainant has proposed an arbitrator or mediator who is acceptable to NIE Networks then the matter should proceed to arbitration or mediation in accordance with the rules set by the arbitrator or mediator.

- 2.3 The above complaints process does not apply to any question of whether or not contested works have been carried out and completed to the satisfaction of NIE Networks. In relation to any such question the decision of NIE Networks is final.
- 2.4 The above complaints process does not affect the ability of a party requiring connection or an ICP to raise any issues of alleged non-compliance with law or licence obligations with the Utility Regulator at any time. However, NIE Networks would expect the complaints process above to have been exhausted prior to any complaint being raised with the Utility Regulator.
- 2.5 The arrangements put in place by NIE Networks to facilitate competition in connection will include documents which set out the requirements of NIE Networks in relation to the asset to be constructed by a party requiring connection or an ICP. The complaints process above may be used by a party which disagrees with NIE Networks' interpretation of such documents but is not intended to operate as a mechanism for review or alteration of those documents. Any party seeking an alteration or amendment to documentation should submit a request in writing to NIE Networks which sets out the element of the documentation which they require to be revised and the reasons for the request. Each request will be reviewed by a senior manager who will provide a written response within 20 working days. Where NIE Networks agrees to the request the relevant documentation will be revised. Regardless of whether or not the documentation is revised NIE Networks will keep a complete record of all requests (including whether they were granted or not and, if refused, the reasons for the refusal) and present that record to the Utility Regulator if the Utility Regulator asks for a copy of it.

Section L – Definitions and Acronyms

Term	Definition
Acceptance of Terms	The relevant form to be completed and signed by the customer to accept either the Full Works Option or the Non-Contestable Works Option.
Adoption Agreement	The agreement covering the ownership transfer of the Contestable Works from the customer or the customer's ICP, as appropriate, to NIE Networks.
Alteration	Works which are required to the customer's existing connection to relocate NIE Networks' equipment. The works must be within the customer's premises and may be under or over ground. The works would not require a change to the Connection Agreement.
Cluster Infrastructure	Transmission and distribution assets that are shared by all parties connecting to a cluster.
Commissioning Tests	The testing of Connection Works after final connection.
Connection Agreement	Means the agreement between the customer and either NIE Networks or SONI governing the Customer's use of the connection after energisation.
Connection Point	A point at which a customer's equipment connects to the Distribution System or the Transmission System, as appropriate.
Connection Works	Works required by a new connection to either the Transmission or Distribution System and which form the local electrical connection between the customer's works and the relevant system. Connection Works do not include Reinforcement Works and may be Contestable Works, Non-Contestable Works or both.
Contestable Connections Policy	The NIE Networks policy document which identifies the policies, specifications and procedures which the customer/ICP shall comply with when undertaking the Contestable Works.
Contestable Works Terms and Conditions	Those terms and conditions issued by NIE Networks applying to the construction of the Contestable Works
Contestable Offer	An offer of connection to the Transmission System which is based on the customer delivering the Contestable Works.
Contestable Works	The Connection Works that are identified in the connection offer which can be carried out by a party other than NIE Networks and SONI (and 'Contestable' will be interpreted accordingly).
Customer	Means, as appropriate, an applicant for a new connection or a party who has accepted a connection offer.
Distribution Licence	The licence granted to NIE Networks by the Department of Enterprise, Trade and Investment under Articles 10(1), 10(6), 11 and 13 of the Electricity (Northern Ireland) Order 1992.
Distribution System	The electric lines within the authorised area, owned by NIE Networks (but not, for the avoidance of doubt, any lines forming part of the Transmission System) and any other electric lines which the Northern Ireland Authority for Utility Regulation may specify as forming part of the Distribution System, including (in each case) any electrical plant and/or meters used in connection with distribution.
Distribution Code	The Code of that name prepared pursuant to Condition 27 of the NIE Networks licence.

Term	Definition
Diversion	Works required by a customer to relocate NIE Networks' equipment in order to, for example, make possible a new connection or facilitate other physical works. The NIE Networks' equipment to be relocated may form part of the customer's existing connection or may be unrelated to the customer's existing connection but will always be located outside of the customer's premises. The works will not require a change to the Connection Agreement.
Easement	A permanent right of retention subject to payment of an initial lump sum.
Electricity Order	The Electricity (Northern Ireland) Order 1992 as revised or amended from time to time.
Energy Order	The Energy (Northern Ireland) Order 2003.
Full Works Option	The option set out in the Terms Letter under which NIE Networks will undertake all of the Contestable Works and all of the Non-Contestable Works.
Grid Code	The Code of that name prepared pursuant to Condition 16 of the SONI licence.
ICP Portal	NIE Networks' website which provides technical specifications, policies and general information for customers and Independent Connection Providers who wish to design and build elements of new electricity connections in Northern Ireland. It can be found here .
Independent Connection Provider or ICP	A person other than NIE Networks or SONI who is accredited to undertake Contestable Works in relation to the provision of a connection to the Distribution or Transmission System.
Lead Developer	The party appointed by all customers at a shared connection to deliver the Shared Contestable Works. The Lead Developer must be one of the customers being connected.
Major Defect	Means a) any issue that, in the opinion of NIE Networks, renders the Contestable Works unfit for the use for which they were intended and/or otherwise unsuitable for use within the NIE Networks Distribution System; and/or (b) any circumstance where the Contestable Works have not been performed and/or delivered in accordance with the terms of the Contestable Offer and/or the Adoption Agreement, whether the Contestable Works are rendered unfit for use or otherwise.
Minor Defects	Minor issues identified in relation to the Contestable Works which, in the opinion of NIE Networks: (a) do not affect the fitness for the purpose for which the Contestable Works are intended; and (b) do not prevent adoption of the Contestable Works by NIE Networks.
Modification	Works which are required to the customer's existing connection as a result of a change of use of the connection and which require a change to the Connection Agreement. For example, a change to the maximum import or export capacity.
Necessary Wayleave	A wayleave granted under Schedule 4 of the Electricity Order.
Non-Contestable Works Option	The option set out in the Terms Letter under which NIE Networks will undertake only the Non-contestable Works.

Term	Definition
Non-Contestable Works	Works that are identified in the connection offer which may only be carried out by either NIE Networks or SONI (and 'Non-Contestable' will be interpreted accordingly).
Point of Connection	The point (or points) of connection between the Contestable Works and the Non-Contestable Works.
Pre-Commissioning Tests	The testing of Connection Works carried out prior to and in readiness for final connection, energisation and Commissioning Tests.
Reinforcement Works	Works that are required by a new connection to either the Transmission or the Distribution System and which are modifications to the existing systems, as compared to new works required to form an electrical connection between the customer's works and the relevant system.
Shared Connection Works	Connection Works that are used by more than one customer.
Shared Contestable Works	Shared Connection Works that are Contestable.
Shared Non-Contestable Works	Shared Connection Works that are Non-Contestable.
Statement of Charges	The statement produced in accordance with either Licence Condition 32 of the NIE Networks Distribution Licence (Statement of Charges for Connection to NIE Networks' Distribution System) or Licence Condition 30 of the SONI Transmission Licence (Transmission Connection Charging Methodology Statement).
Terms Letter	The letter issued by NIE Networks offering terms for connection to the Distribution System.
Transmission Connection Offer	An offer of connection to the Transmission System and is either a Non-Contestable Offer or a Contestable Offer.
Transmission Licence	Either the transmission licence granted to SONI by the Department of Enterprise, Trade and Investment under Article 10(1)(b) of the Electricity (Northern Ireland) Order 1992 or the transmission licence granted to NIE Networks by the Department of Enterprise, Trade and Investment under Articles 10(1), 10(6), 11 and 13 of the Electricity (Northern Ireland) Order 1992, whichever is appropriate.
Transmission System	The system of electric lines owned by NIE Networks and comprising high voltage lines and electrical plant and meters used for conveying electricity from a generating station to a substation, from one generating station to another, and from one substation to another within the authorised area (including such part of the North/South Circuits as is owned by the NIE Networks) (except any such lines which the Northern Ireland Authority for Utility Regulation may approve as being part of NIE Networks' Distribution System) and any other electric lines which the Northern Ireland Authority for Utility Regulation may specify as forming part of the Transmission System, but shall not include any Interconnector.
Unique Connection Works	Connection Works that are used by only one customer.
Unique Contestable Works	Unique Connection Works that are Contestable
Unique Non-Contestable Works	Unique Connection Works that are Non-Contestable
Utility Regulator	The Northern Ireland Authority for Utility Regulation established under the Energy Order

Term	Definition
Wayleave	A contractual licence granted by a landowner permitting retention of equipment subject to certain terms.

Appendix 1 – Contestability Boundaries for a Generation Spur Connection

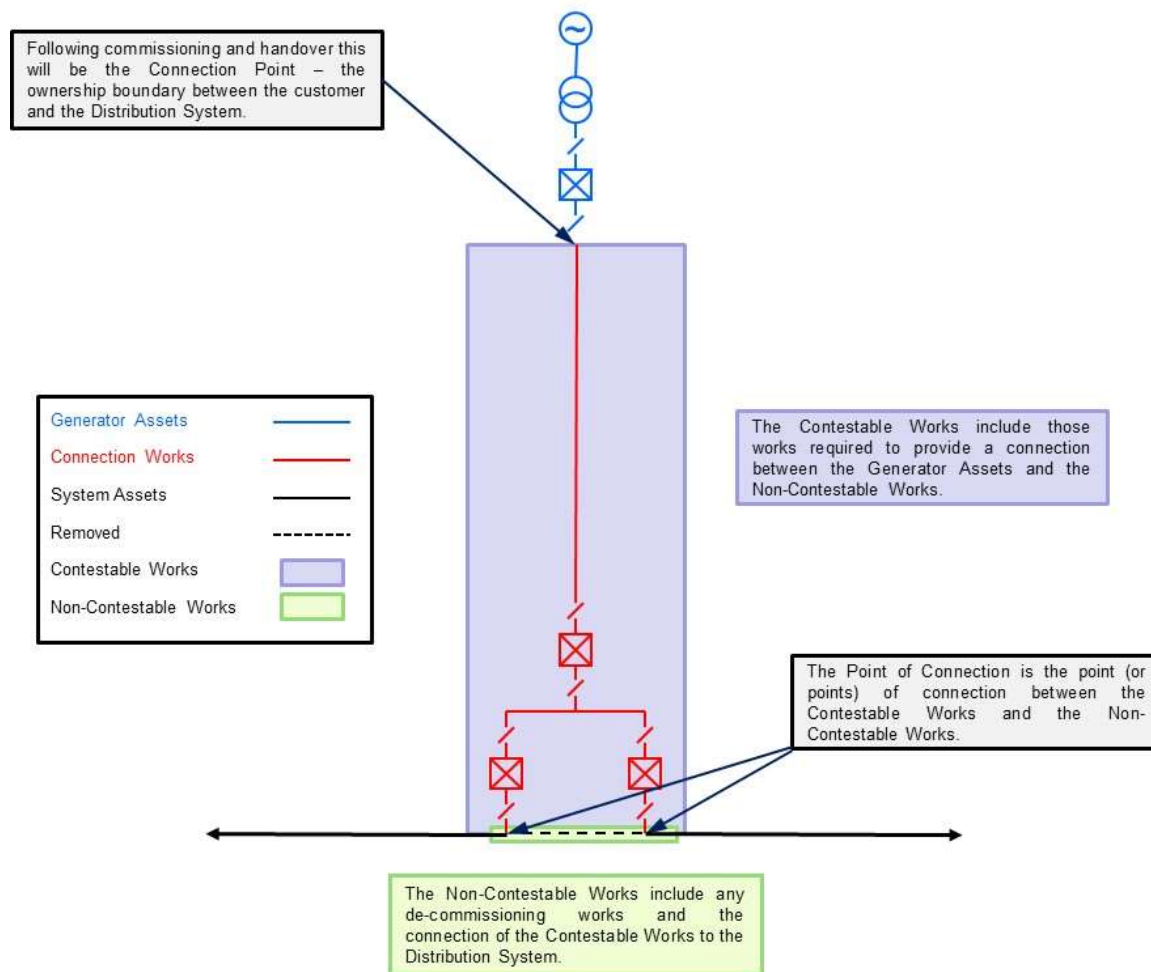

Appendix 2 – Contestability Boundaries for a High Voltage Demand Customer

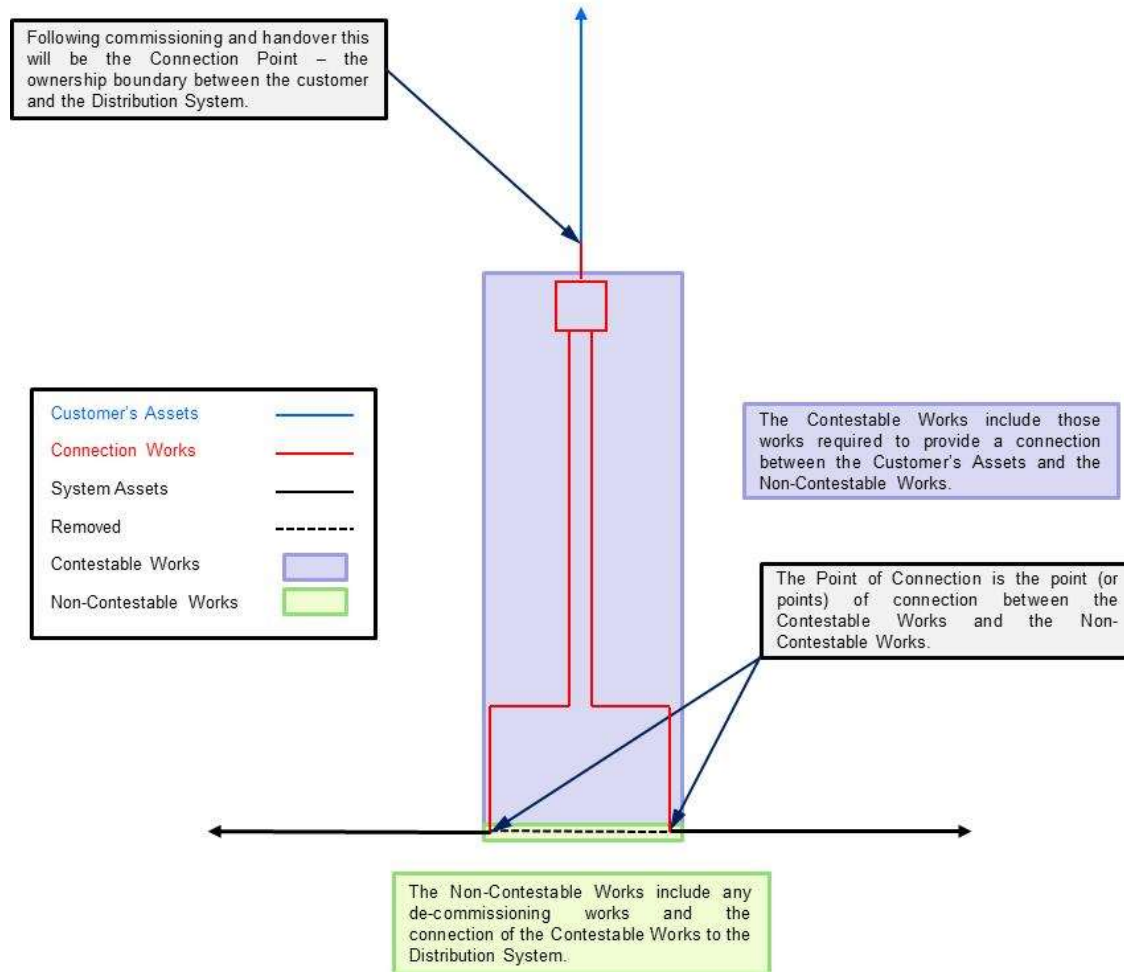

Appendix 3 – Contestability Boundaries for a Low Voltage Demand Customer

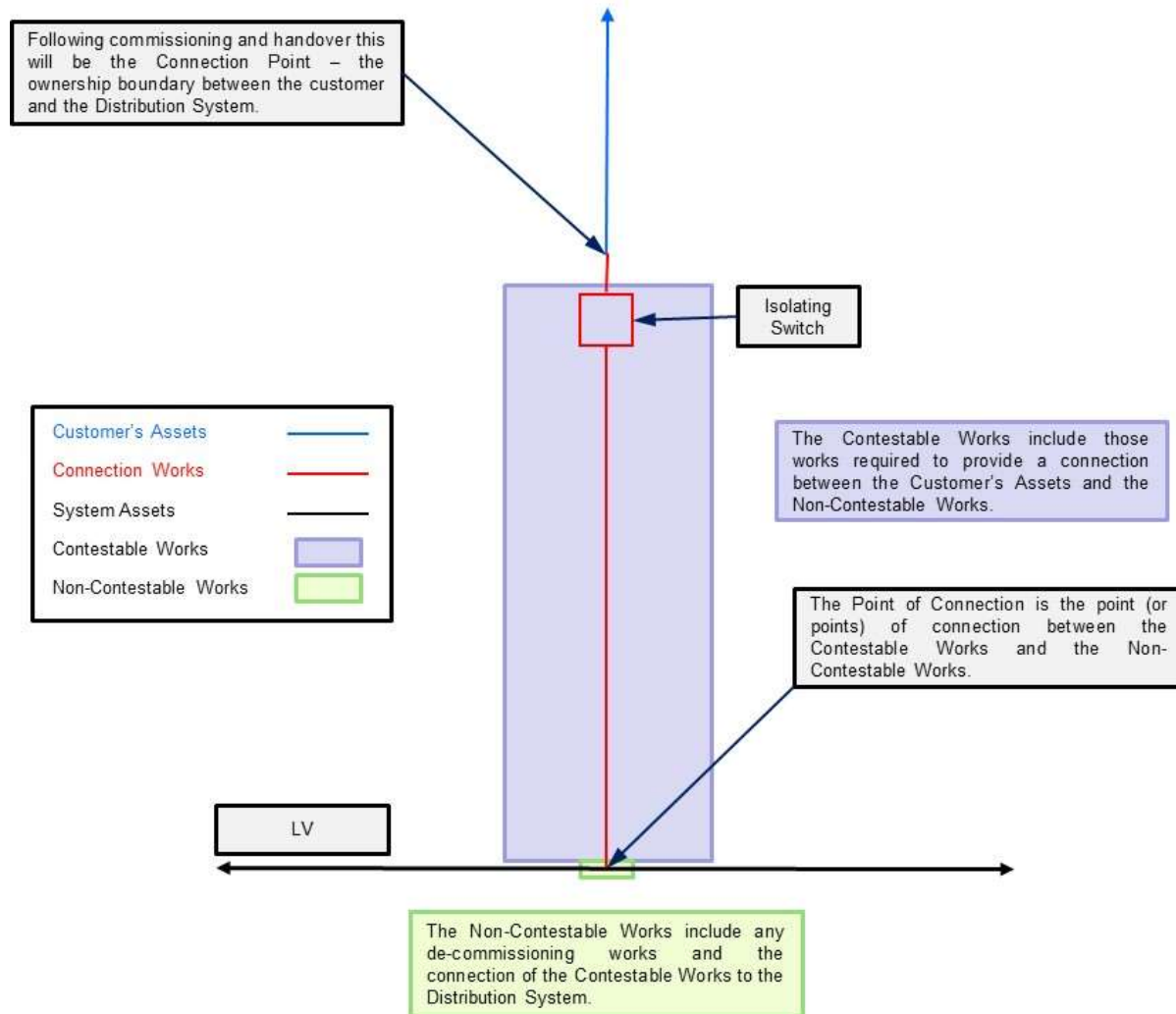

Appendix 4 – Contestability Boundary in a New Underground Supply

- If POC joint-hole is on public property, this is Non-Contestable
- Trenching on public property is Contestable

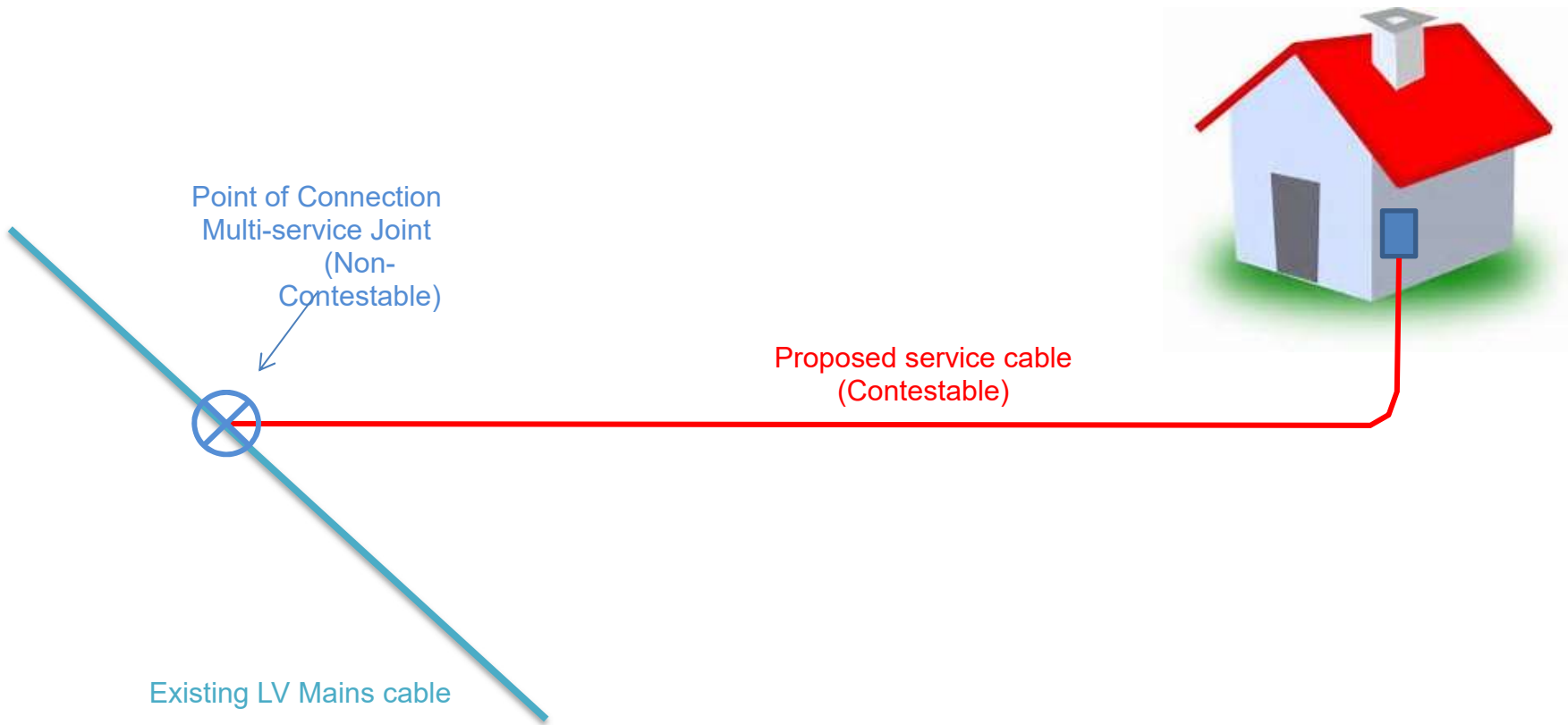

Appendix 5 – Contestability Boundary – New transformer on existing pole

- A new pole in-line is Non-Contestable
- Survey / Wayleaves to be split between Contestable and Non-Contestable

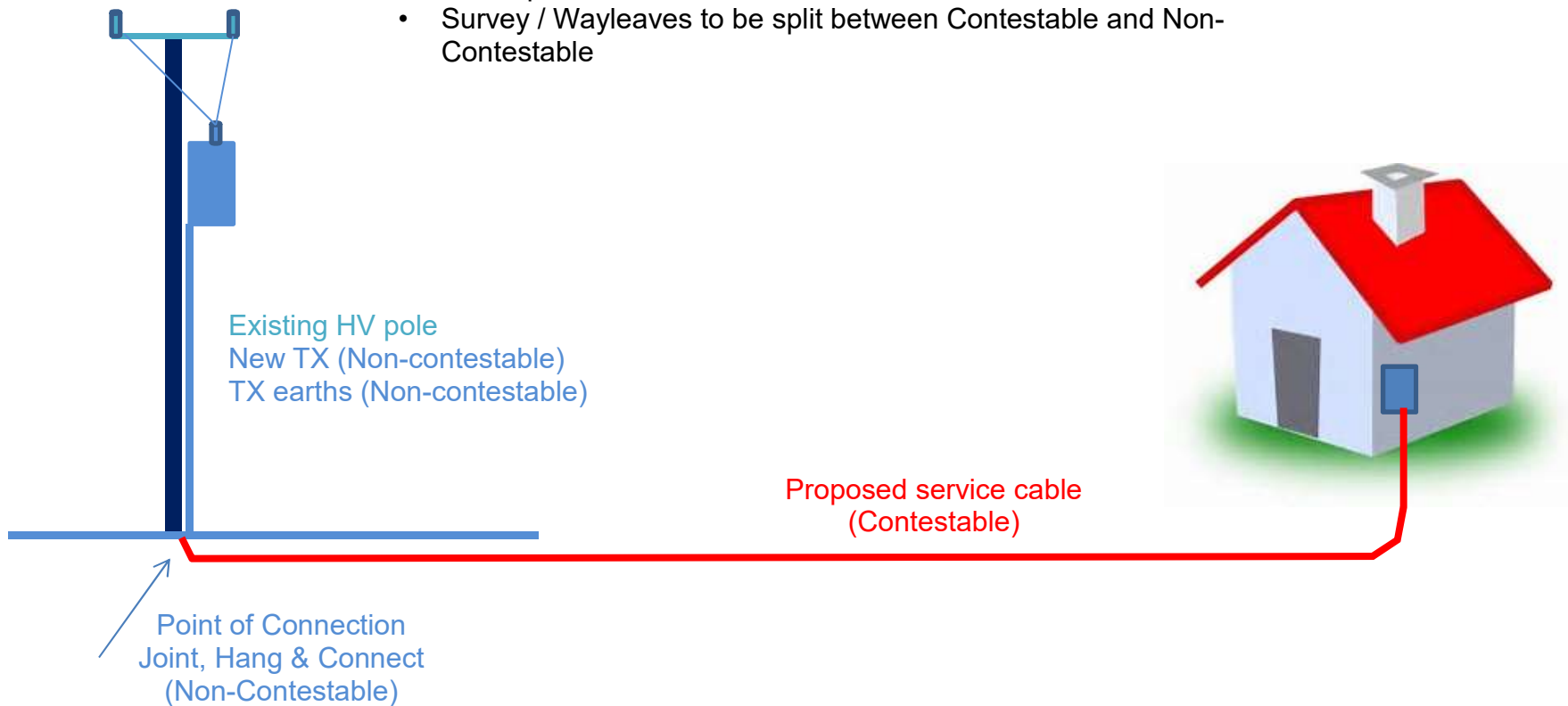

Appendix 6 – Contestability Boundary – New two span spur plus transformer

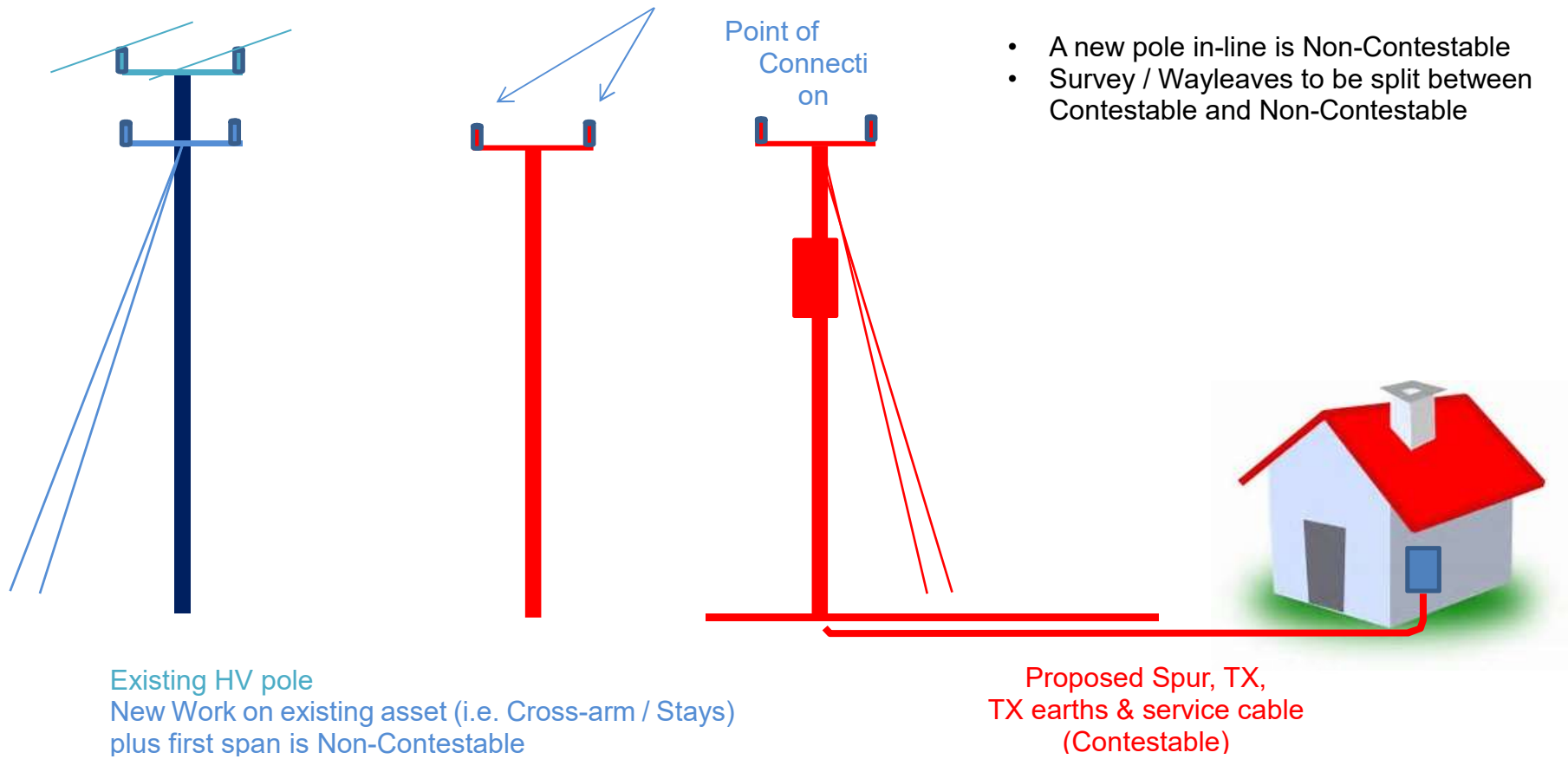

Appendix 7 - High Level Process for Contestable Delivery of a Distribution Connection

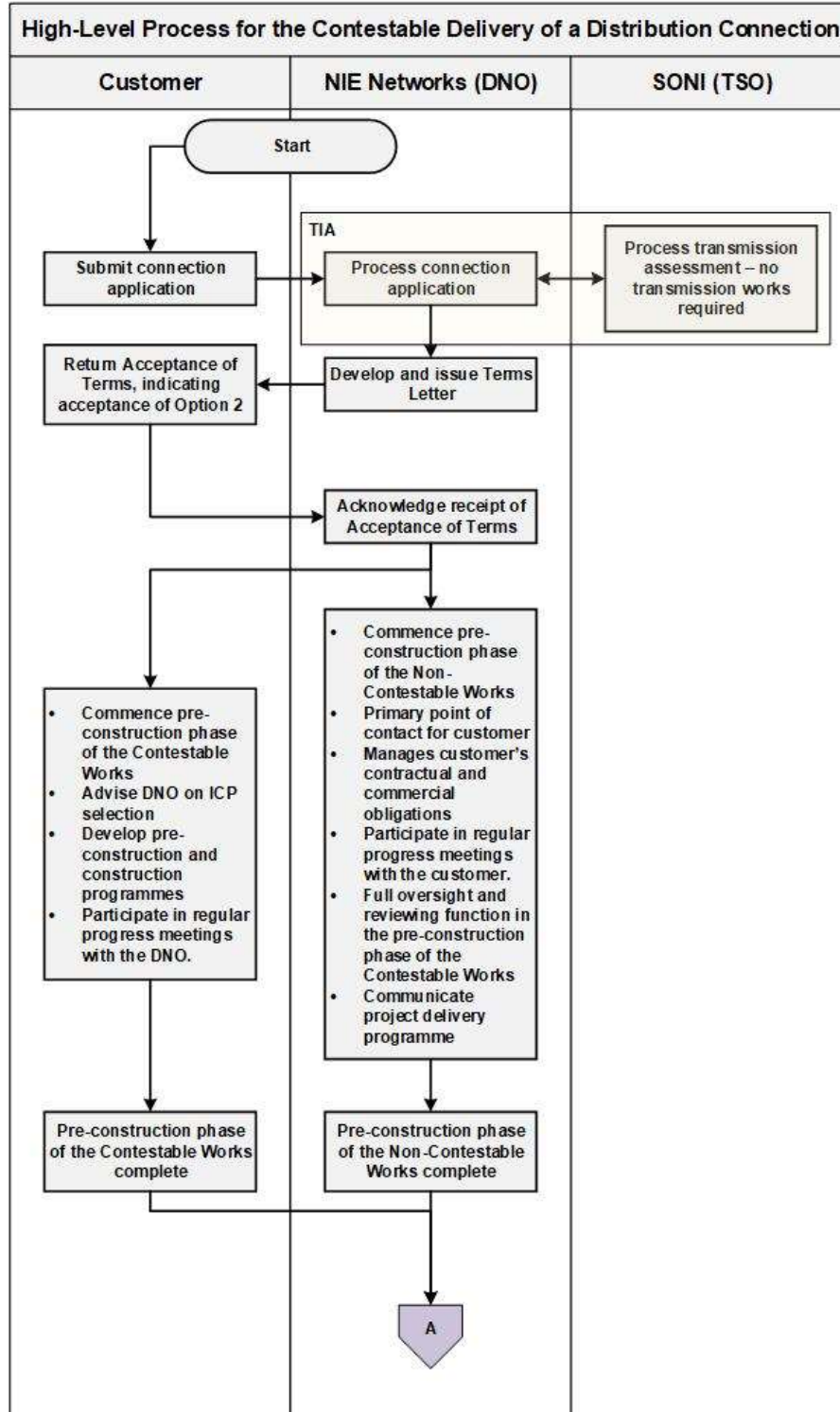

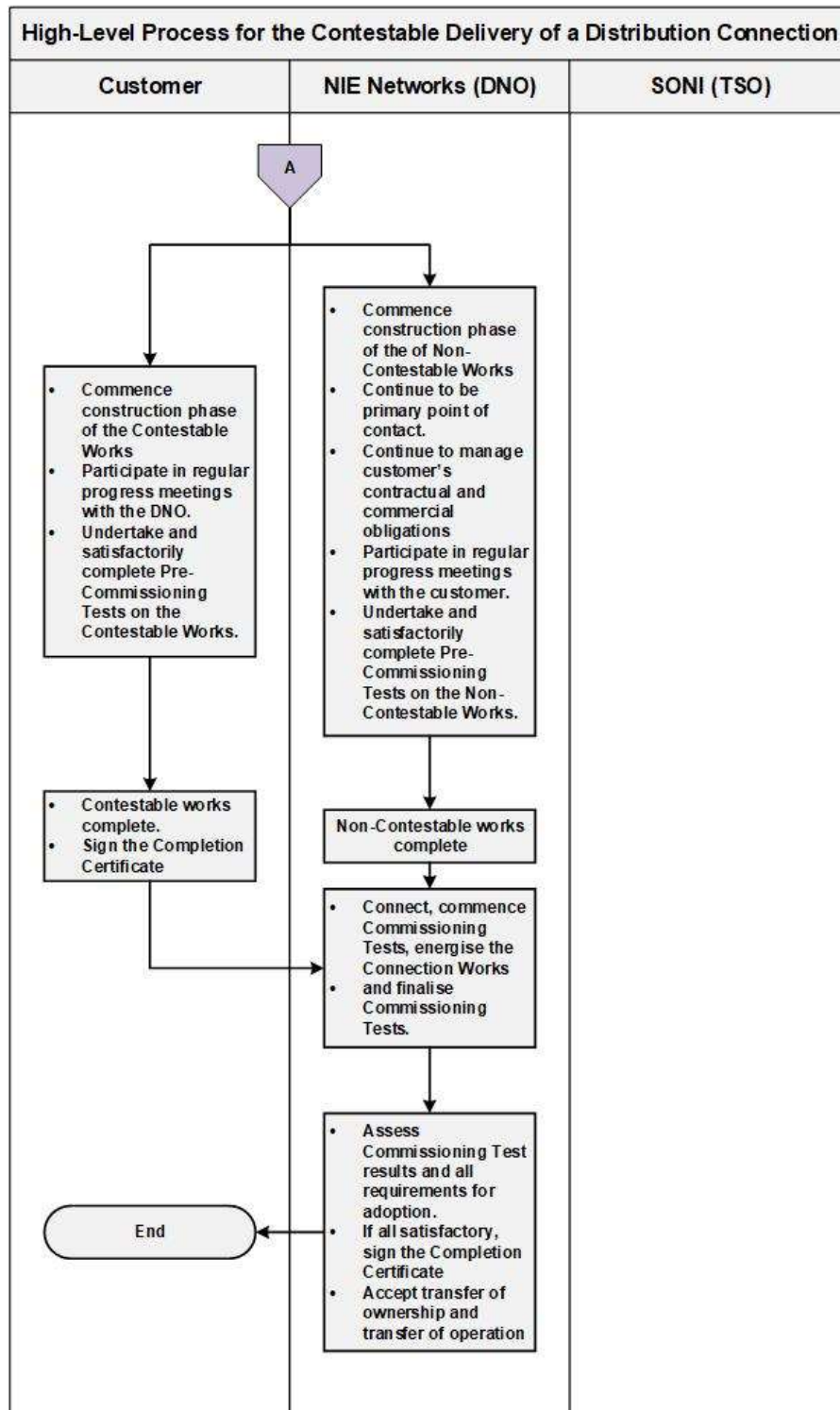

Appendix 8 - Contestability Boundaries for Shared Connection Works to the Distribution System

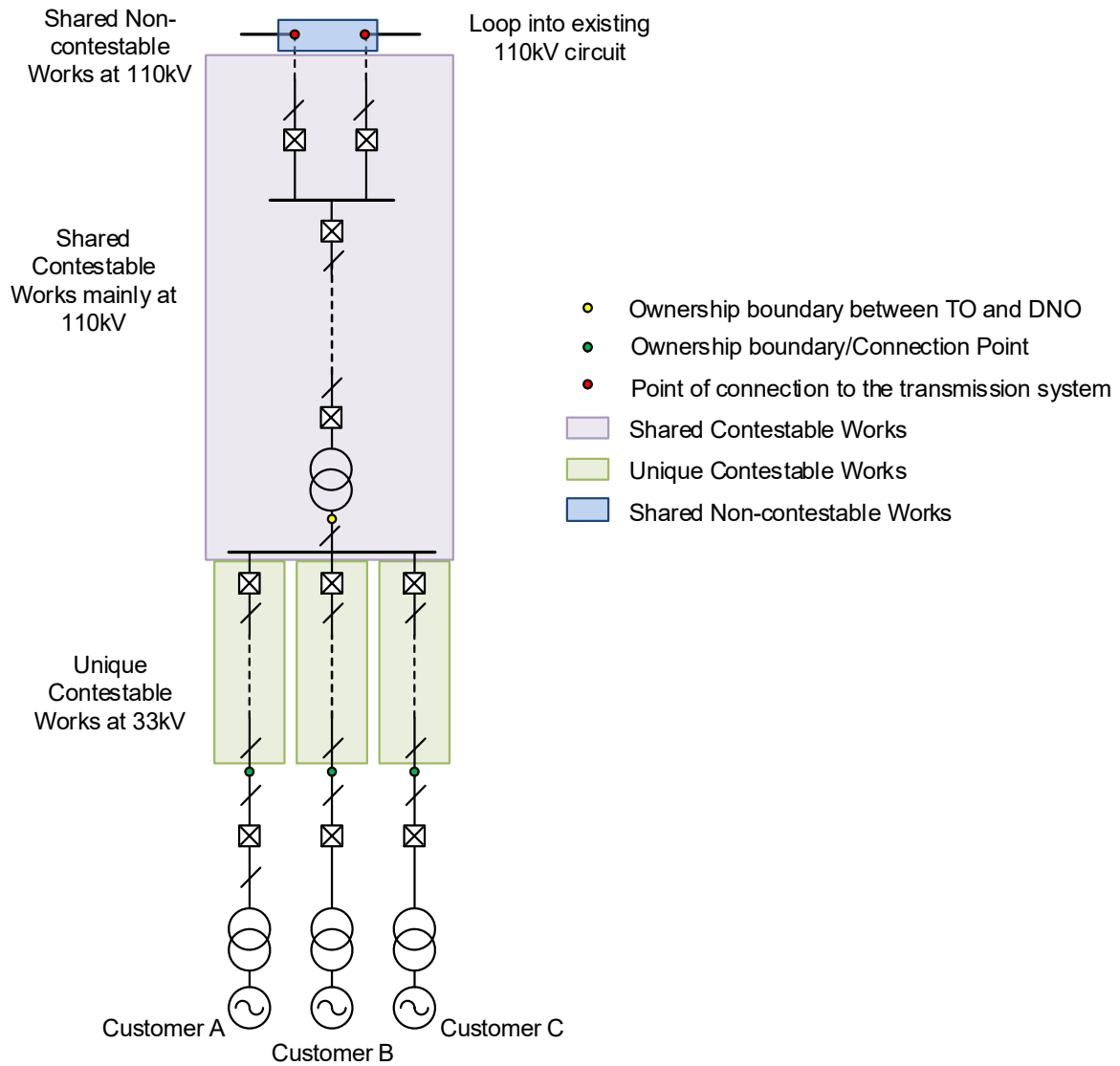

Appendix 9 - High-Level Process for the Contestable Delivery of a Cluster

